

AIR JET COOLERS FOR MOLD

— COMPACT TYPE —

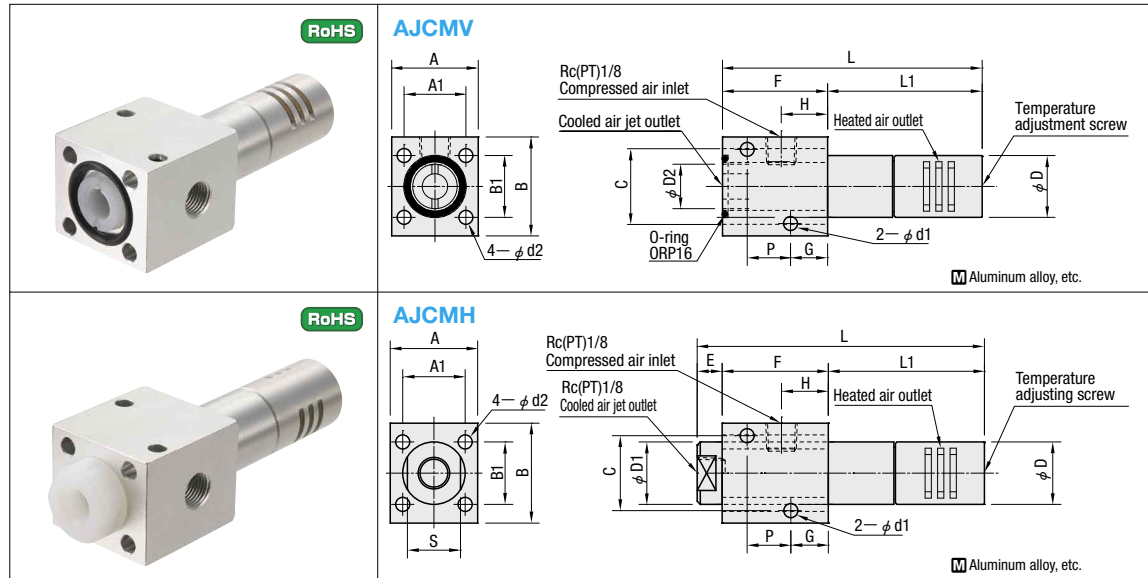

Common												Rc(PT)	AJCMV		AJCMH			Part Number		U/Price	
L1	F	H	G	P	C	d1	d2	D	A	A1	B		B1	D2	L	E	D1	S	L		Type
50	34	15	12	14	24	4.5	4.5	20	28	20	32	20	1/8	14.4	84	—	—	—	AJCMV	150	
															8	20	17	92	AJCMH	150	
106	52	23	18	24	36	6.6	5.5	32	40	30	46	30	3/8	—	—	12	30	26	170	AJCMH	600

Order **Part Number** AJCMV150 **Price** **Quotation**

Days to Ship **Quotation**

Characteristics

- The cooler produces cool air such that the maximum temperature difference is -55°C compared to the entered temperature by providing compressed air.
- The cooler efficiently cools narrow holes that cannot be cooled by cool water and leaky parts and improves cycle time.
- Effective at locally cooling molded parts.

Usage

- Use the cooler with 0.3~0.7MPa of pressure.
- Use an air dryer to provide dehumidified air and set an air filter (filtration $40\ \mu\text{m}$ and lower) and an oil mist separator to prevent foreign objects from getting in.
- Be careful not to burn yourself with hot air from the heat release outlet.
- Release air that cooled a mold from the cool air jet outlet into the air. If you do not release it, cool air will stop.
- If the air is noisy, apply any silencer.

Breakdowns and repairs

- If cooling gets less effective, follow the procedure below for check.
 - Readjust the temperature adjusting screw.
 - Check if a clogged filter or mist separator causes reduction of pressure.
 - Check if enough air consumption on the right page is provided.
- We assume no responsibility for dismantled products.

Cool air temperature adjusting method

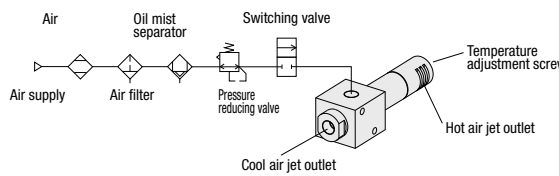
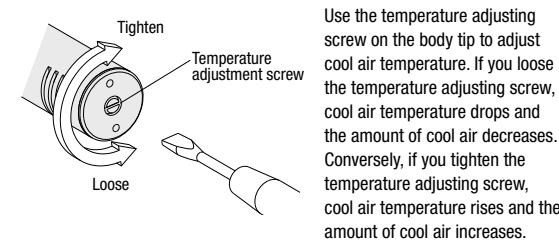

air consumption

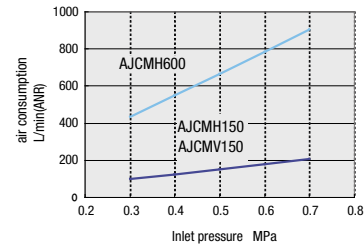

Temperature · Heat amount characteristic

- The air descent temperature is the descent temperature against the air temperature at the entrance.
- When the adjusting screw is completely tightened, the value for the number of adjusting screw rotations is 0.
- The following graph shows a characteristic of the air jet cooler only.
- Amount of heat (W) is power that cool air from the cool air jet orifice can draw from cooling objects. $1\text{W}=0.86\text{kcal/h}$

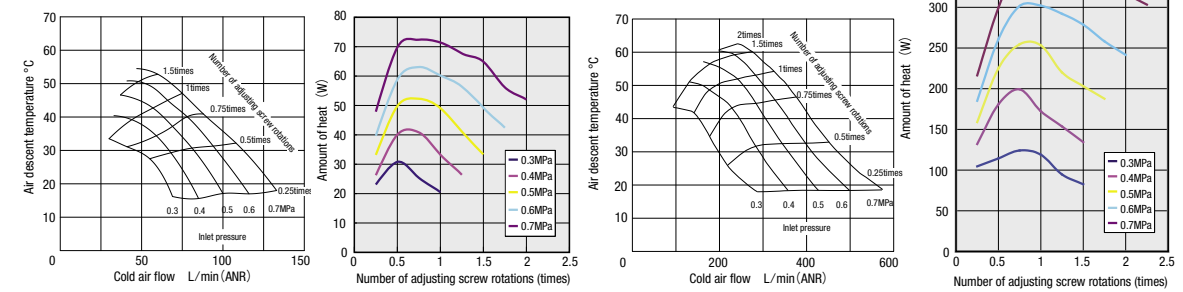

Example of how to mount

- Screw a cooler on the side of a mold for direct flow of cool air. (Photo1)
 - ※With AJCMV mounted
- Set a cooler near the side of a mold and use pipes and the like for flow of cool air. (Photo2)
 - ※With AJCMH mounted

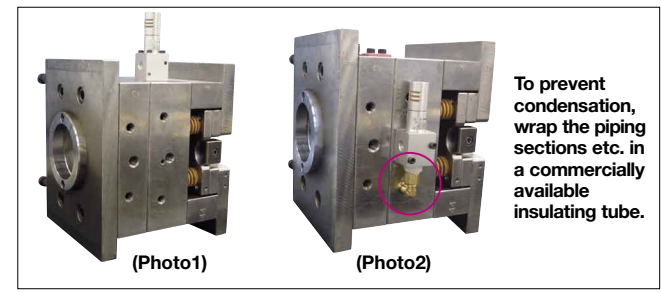

Explanation

Principle of cool air separation
As the following diagram shows, compressed air sent to this device is forcibly rotated at high speed in the device to separate cool air from hot air, which applies the principle of vortex theory. For this phenomenon, only cool air can be taken out.

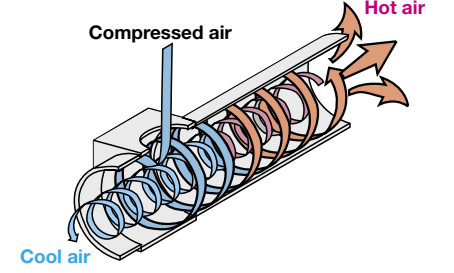

Example

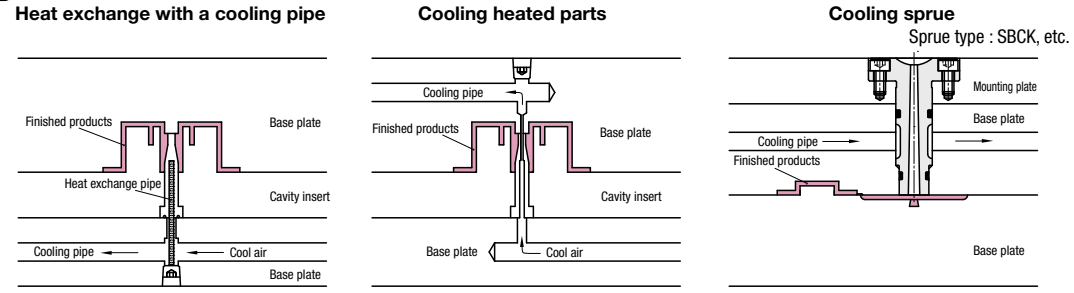

Air jet cooler peripheral parts

Joists for low temperature
 Straight (P1092) M-NSC M-NKC
 L-shaped (P1092) M-NSL M-NKL
 Screw adapter joints (P1097) JEMM JEMMR
 L-shaped joints (P1099) JEFLR JEFLR

Tubes for low temperature
 M-SFT (P1107)

Fluorine resin
Possible temperature of use $-65\sim 180^{\circ}\text{C}$